



E61 HIGH DENSITY FILM CAPACITORS FOR LEAN BUFFER CIRCUITS



The Clever Alternative to Electrolytic Capacitors

ELECTRONICON[®]
always in charge

THE „LEAN“ BUFFER CIRCUIT

3-Phase Frequency converters with Low-Capacitance DC-Link (LCDC)

Robots, elevators, assembly lines, processing centers, tooling machines - high process speed and further improvement of automation levels are unthinkable without frequency controlled AC drives. And it would not be possible to achieve the optimum operating characteristics at an economically feasible utilization level of available resources.

Most of the contemporary 3-phase frequency converters are working with a DC link, mainly using electrolytic capacitors to buffer the DC voltage. When selecting the electrolytic capacitors, the dominating criteria are the AC current load and the required operating life time. As a rule, this leads to the installation of large banks of electrolytic capacitors even though the large capacitance as such would not even be necessary for the buffering.

These days, decentralized motors with integrated drive are becoming more and more popular. The advantages of this topology are more intelligent and flexible interconnection and control of the individual systems, as well as simplified and more convenient maintenance conditions. At the same time, developers are tasked to improve the technical performance of the electronic drives, reduce their mechanical dimensions and - of course - cost.

The „LCDC“ (DC buffer circuit with small capacitance) complies with all these requirements and has become available thanks to the high density DC film capacitors designed and manufactured by ELECTRONICON.

Example:

A 1.5kW frequency converter with electrolytic capacitors, pic 1a.

A comparable solution using LCDC is shown in pic 1b.



- **LESS COMPONENTS, WEIGHT AND COST**
- **REDUCED POWER LOSSES**
- **ENHANCED RELIABILITY (LOW FIT RATE)**
- **LONG OPERATING LIFE**

The following compares a DC link with electrolytic capacitors and MKP film capacitors of our E61 series by the example of a **5kW drive** ($T_{\text{ambient}} = 70^{\circ}\text{C}$, target life time = 50.000 h):

DC link with electrolytic capacitors
Pic 2a

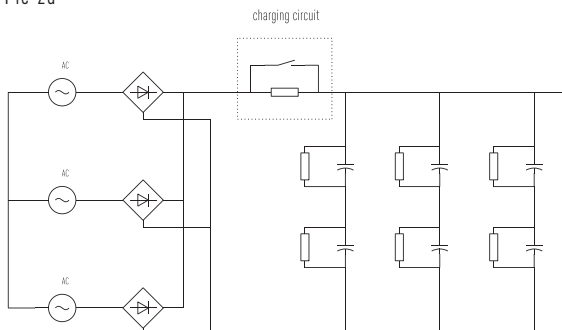

LCDC link with MKP capacitors
Pic 2b

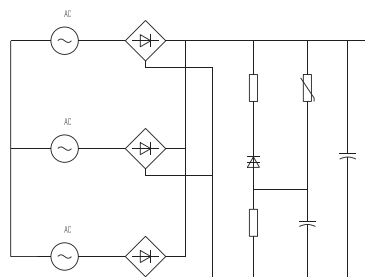

DIMENSIONS AND TECHNICAL FEATURES (5kW)



	Elyt* 1300 μ F/450V	E61 48 μ F/900V
ESR/300Hz	110 m Ω	4.3 m Ω
$I_{\text{rms}}/300\text{Hz}$	8 A	35 A
D x L	40 x 96 mm	50 x 57 mm
Volume per unit	120 cm ³	112 cm ³
Weight per unit	170 g	120 g
Required quantity	6	1
Total volume installed	6 x 120 cm ³ = 720 cm ³	112 cm ³
Total weight installed	6 x 170 g = 1020 g	120 g

* example: market-leading Japanese manufacturer

INTERACTIONS WITH MAINS

The comparison of mains currents in pic.3 shows that the necessity for filtering is substantially reduced as well:

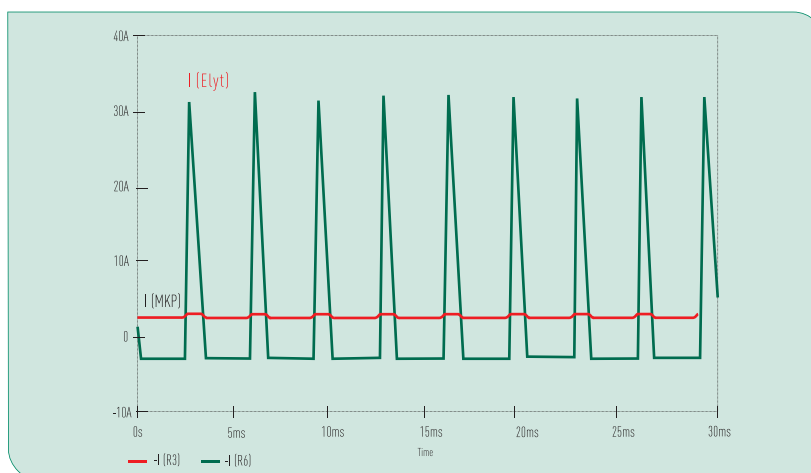

COST ADVANTAGES

Presuming that the expenses for the sharing resistors and the charging circuit of the electrolytic capacitors equals more or less the cost of the additional buffering for the MKP circuit, we can achieve a cost reduction by factor 5 when using MKP capacitors instead of electrolytic capacitors. This does not yet consider indirect savings by improved reliability of the final product, reduced power losses a.o.

YOU WOULDN'T HAVE THOUGHT: SIMPLY BETTER

Film capacitors can save space and cost in your DC Link

The capacitors of the E61 series are optimized for use in DC Link circuits with high rms and surges currents. The pin terminals allow for direct integration into your printed circuit board.

Along with their high specific ratio of capacitance to volume, they offer excellent self-healing without loss of capacitance, long term stability, and long storability.

The winding is placed inside a flame retardant housing filled with solid resin (PUR). In order to minimize self-inductance and dimensions, the E61-capacitors are not equipped with an internal fail-safe device. Capacitors with their comparably high fire load (appr. 40MJ/kg) do always bear a certain risk of collateral damage in the event of a failure. It is therefore necessary to place them in uncritical environment or integrate other proper measures of prevention.

Technical Data:

Standards	IEC 61071, optional IEC 61881
can	plastic
mounting position	optional
filling material	solid, based on vegetable oil, non-PCB
internal protection	none
fire load	40 MJ/kg
C_N tolerance	±5%

insulation strength $C \times R_{is}$	5000 s
$\tan\delta_0$	2×10^{-4}
operating temperatures	
Θ_{min} Θ_{max}	-40 ... +85°C
$\Theta_{HOTSPOT}$	≤ 85°C
storing temperature	-40 ... +85°C
FIT Rate	50 FIT
(reference service life 100 000 h, $\Theta_{HOTSPOT} \leq 70^\circ\text{C}$)	

C_N μF	R_S mΩ	R_{th} k/W	I_{max} A	\hat{I} kA	I_S kA	W_N W_S	L_e nH	$D_1 \times H$ (mm)	Design	m kg	Order no.
U_N 500V DC			U_r 230V			U_S 750V		U_{BB} 750V DC			
85	2	10.9	35	1.1	3.3	11.9	45	50 × 57	P3	0.12	E61.G57-853P30
195	3.4	7.4	32	1.1	3.3	24.4	66	50 × 95	P3	0.18	E61.G95-204P30
260	5.2	6.1	30	1.1	3.3	32.5	85	50 × 120	P3	0.21	E61.G12-264P30
U_N 700V DC			U_r 230V			U_S 1050V		U_{BB} 1050V DC			
58	1.9	10.9	30	0.9	2.7	14.2	45	50 × 57	P3	0.12	E61.G57-583P30
142	3.5	7.4	32	0.93	2.8	34.8	66	50 × 95	P3	0.18	E61.G95-144P30
190	4.7	6.1	25	0.91	2.73	46.6	85	50 × 120	P3	0.21	E61.G12-194P30
U_N 900V DC			U_r 300V			U_S 1350V		U_{BB} 1350V DC			
36	2.4	10.9	35	0.7	2.1	14.6	45	50 × 57	P3	0.12	E61.G57-363P30
45	2.1	10.9	35	0.8	2.4	18.2	45	50 × 57	P3	0.12	E61.G57-453P30
48	2.2	10.9	35	0.85	2.55	19.4	45	50 × 57	P3	0.12	E61.G57-483P30
112	4.1	7.4	32	0.84	2.52	43.7	66	50 × 95	P3	0.18	E61.G95-114P30
155	6	6.1	30	0.85	2.55	62.8	85	50 × 120	P3	0.21	E61.G12-164P31
U_N 1100V DC			U_r 300V			U_S 1650V		U_{BB} 1650V DC			
30	2.8	10.9	20	0.64	1.92	18.2	45	50 × 57	P3	0.12	E61.G57-303P30
73	4.5	7.4	25	0.66	1.98	44	66	50 × 95	P3	0.18	E61.G95-733P30
100	6.1	6.1	25	0.66	1.98	60.5	85	50 × 120	P3	0.21	E61.G12-104P30
U_N 1300V DC			U_r 300V			U_S 1950V		U_{BB} 1950V DC			
12	4	10.9	20	0.38	1.14	10	45	50 × 57	P3	0.12	E61.G57-123P30
16.5	3	10.9	20	0.47	1.41	14	45	50 × 57	P3	0.12	E61.G57-173P30
40.5	5.7	7.4	25	0.49	1.47	34	66	50 × 95	P3	0.18	E61.G95-413P30
55	7.7	6.1	25	0.49	1.47	46	85	50 × 120	P3	0.21	E61.G12-553P30



Design P3

Side view dimensions: Diameter = 50, Total height = L_T , Terminal height = 4.

Top view dimensions: Diameter = 37.5, Terminal diameter = $4 \times \varnothing 1.2$, Internal diameter = $\varnothing 2$, Terminal offset = 16.

Connection diagram

Can material flame-retardant plastic can
 filled with solidified PUR resin
 Terminals copper wire $\varnothing 1.2 \text{ mm} / 2 \text{ mm}$
 I_{max} (Terminals) 35 A
 Degree of protection IP 00
 K 17.5 mm
 L 17.5 mm
 Humidity class F



EXCELLENT EXPERIENCE IN CAPACITOR MAKING FOR OVER 70 YEARS

Gera has been a centre of capacitor making since 1938. ELECTRONICON Kondensatoren GmbH which emerged from previous RFT/VEB ELEKTRONIK Gera in 1992, has become one of Europe's leading capacitor manufacturers supplying customers worldwide and being an open and competent partner for manufacturers and users of power factor correction equipment, for many manufacturers of drives, power electronics, home appliances, and for the lighting industry. Regular investments in advanced and environmentally sound technologies guarantee the highest levels in manufacture and quality to modern standards which are approved and monitored by leading certification authorities.



In today's globalised competition, we distinguish ourselves by

- Absolute reliability and safety of our products
- Close co-operation between manufacturer and client to meet both technical and commercial requirements
- Improvement and development of our technical expertise in capacitor design and manufacture, as well as film coating, with special attention paid to the MKPg-technology
- Early identification and incorporation of new trends and methods in the manufacturing of capacitors
- Flexibility and punctual fulfilment of our commercial obligations

Our experienced development engineers are competent and responsible for both implementing the latest technical trends applicable to our products and ensuring that our products adapt to the challenges of traditional and new markets. The close and intense co-operation between the departments of Marketing & Sales, Research & Development, and Production has become the keystone of our success. ELECTRONICON is continually striving to establish a similarly close and interactive relationship with its distributors and direct clients both in home and overseas markets, to become not just one out of many suppliers, but your preferred partner for ideas and solutions.

ELECTRONICON®

Germany • 07549 Gera • Keplerstrasse 2
Fon +49 365 / 734 61 00 • Fax +49 365 / 734 61 10
E-Mail: sales@electronicon.com, www.electronicon.com

